

OWNER'S MANUAL



SLUGMASTER



P 0800 853 002
E info@yelo-agri.com
W www.yelo-agri.com

PARTS & SUPPORT

For parts and service support, contact your authorised Yelo store or visit our website for store locations. If you need further assistance, we are only a phone call or email away. Parts list included.



SAFETY PRECAUTIONS

SLUGSLUGMASTERASTER

AN IMPORTANT MESSAGE FOR OWNERS & OPERATORS OF Yelo ATTACHMENTS/ACCESSORIES

Be warned of the dangers of loading your ATV or other vehicle in excess of its carrying capacity. It is important to understand that any loads or attachments whether fastened to or placed on a vehicle or ATV will alter the stability or handling characteristics of that vehicle or ATV.

Spreaders or other equipment must be filled only to a level where the gross weight is within the load limit of the ATV or other vehicle.

Safety is a primary concern in the design, manufacture, sale, and use of spreaders and other equipment. As manufacturers of spreaders and other equipment we want to confirm to you, our customers, our concern for safety. We take this opportunity to remind you about the simple, basic and common sense rules of safety when using spreaders and other equipment. Failure to follow these rules can result in severe injury or death to operators and bystanders.

It is essential that everyone involved in the assembly, operation, transport, maintenance and storage of this equipment be aware, concerned, prudent and properly trained in safety.

This also applies to equipment that is loaned or rented to someone who has not read the owner's manual and is not familiar with the operation of application equipment.

- NEVER EXCEED THE LOAD LIMIT CAPACITY OF THE ATV OR OTHER VEHICLE.
- ALL ATV AND TRAILED EQUIPMENT TYRES SHOULD BE INFLATED TO MANUFACTURERS RECOMMENDED OPERATING PRESSURES.
- PLEASE NOTE THAT FILLING THE SPREADER OR OTHER EQUIPMENT COMPLETELY AND OR THE ATTACHMENT OF ADDITIONAL EQUIPMENT TO THE ATV MAY EXCEED THE ATV'S MAXIMUM LOAD CAPACITY AND IT IS NOT RECOMMENDED TO EXCEED MANUFACTURER GUIDELINES

Cautions, Warnings and Notes.

Throughout this document text has been highlighted as warnings, cautions and notes. Warnings are mandatory instructions. Failure to comply with these instructions may result in injury or damage. Cautions are advisory. Failure to comply may result in poor operation or premature failure. Notes are to assist with convenient operation of the equipment.

NOTE

To calculate the gross weight of your spreader the conversion rate is 1 litre of water equals 1 Kg

WARNING

For safe operation ensure that your vehicle is adequate for the task. The maximum tare weight is 60 Kg.

Read the instruction book thoroughly before attempting to install or operate the spreader. Failure to read the manual constitutes misuse of the equipment and will invalidate the warranty.

The maximum loaded weight of the spreader should not exceed the manufacturers specific carrier weight limit.

Never turn the spreader on if there is someone standing near the spinner.

Make sure the spinner is turned off and the shutter is closed before loading the hopper.

Never use dirty product or product with stones or lumps.

Never replace the fuse with one larger than the maximum recommended rating of 20 amps.

If using the spreader on hilly terrain, the payload should be reduced to ensure that the spreader and vehicle stability are not compromised.

Never allow anyone to ride on the spreader.

Keep the spreader in good condition. Cleanliness and maintenance are essential for safe and trouble free operation.

Never leave product in the hopper or store the spreader without cleaning it.

Yelo SLUGMASTER G3

OWNER'S MANUAL

(Pt. No. 2400-6700 Issue 24)

TABLE OF CONTENTS

2	Safety Precautions
4	Contents
5	Introduction
	Description
6	Specifications
7	Optional Equipment
	Warranty
	Liability
9	Installation
10	Wiring
11	Operation
12	Calibration
	Calibration Guide
13	ADJUSTING THE DELIVERY CHUTE FOR HIGH OR LOW RATES
14	ADJUSTING/CENTRING THE SPREAD PATTERN
15	Operating the Spreader
16	Maintenance
	Before Use
	After each use and daily when in use
	Hints
16	Trouble Shooting
17	Parts Diagram
18	Notes

INTRODUCTION

Congratulations. You have just purchased an advanced spreader from RGL. RGL is committed to providing you, the farmer, with quality applying systems.

DESCRIPTION

The Yelo Slugmaster is designed for accurate application of slug pellets. It can also be used for application of other products such as grass seed and trace elements.

The uniquely designed 75 litre translucent non-corrosive polyethylene hopper is specially profiled for good product flow and ease of filling. The convenient hinged polyethylene snap shut lid ensures secure product storage. A high quality agitator and stainless steel shutter and choke assembly ensures even and controlled flow of product to the spinner. An electric actuator ensures a positive open, closed action of the shutter. A unique three vane stainless steel spinner driven by a 12 vdc motor provides 180 degrees spread of product.

The Slugmaster can be mounted in two different ways:

- The Slugmaster can be bolted to a flat vertical surface. (Standard)
- The Slugmaster can be mounted with the convenient Quick Smart™ attachment system for ATVs.
 - o QS Frame 1073
 - o QSA Attachment bracket 3008

SPECIFICATIONS

(Specifications subject to change without notice)

Dry Weight	19 Kg	
Dimensions	Width	600 mm
	Height	900 mm
	Length	500 mm
Capacity	75 litre	
Power Consumption	12 vdc 9.5 amps (Typical)	
Drive	12 vdc motor with remote control switch	
Control	Adjustable stainless steel slide choke	
Shutter	Dual 12 vdc electric actuators with remote control switch	
Control Panel	Supplied with 1.5M battery cable, and 2M control cable	
Agitator	Mechanical arm	
Spinner	Stainless steel 3 vane spinner	
Hopper	Non-corrosive polyethylene, ergonomically designed for ease of filling and inspection	
Hopper Lid	Non-corrosive polyethylene snap shut	
Frame	Powder coated zinc plated steel	
Application rate (Low Range)	2.5-6.0 Kg per hectare at 12 kph (nominal slug pellets)	
Application rate (Max)	6.0-20 Kg per hectare at 12 kph (nominal slug pellets)	
Spread width	24 m (nominal pallets)	
Optional equipment	Control Cable Extensions, 3Metre (Two required)	Pt.No.1500-4700
	QuickSmart spreader Frame Kit, QS ATV	Pt.No.3008
	QuickSmart ATV Frame	Pt.No.1073
	QuickSmart RTV Frame	Pt.No.1113
Order Information	Slugmaster	All markets unless specified Pt.No.3011

OPTIONAL EQUIPMENT

Extension Cables. If the spreader is to be placed at a distance from the control panel, optional control cable extensions can be used. These are available in 3.0 metre lengths. Two additional cables are required for each extension, one for the shutter control and one for the spinner motor. Simply plug the extension cables into the control cables and connect them to the spreader connectors. Stow any excess cable where it cannot be pinched or damaged.

Extending the Battery Cable. If the Control Panel is to be placed at a distance from the vehicle battery, the battery cable may need to be extended. The cable can be cut and the optional connector set (Pt No. 6250-3000 and 6250-3001) installed on the ends of the wires. The Male connector must be installed on the Control Panel cable. The cable can then be extended by adding a 3.0 metre extension cable.

CAUTION

To avoid damage to the Control Panel electronics the red wire must be connected to the inner pin of the britax connector.

WARRANTY

1 WARRANTY AND LIABILITY

Use of the equipment

- 1.1 You must satisfy yourself as to the suitability of the equipment for your intended use(s) of the equipment.

Your relationship with the retailer

- 1.2 Where you consider you have a warranty claim (or any other claim) in relation to the equipment, you must contact the retailer who sold you the equipment, not RGL directly. The retailer is responsible for liaising with RGL in respect of your claim.

Warranty

- 1.3 RGL warrants to the original purchaser that the equipment is sold free from defects in materials and workmanship for a period of 12 months from date of first retail sale subject to the terms set out below.
- 1.4 RGL will at its option repair or replace the defective equipment (or part of the equipment) or notify the retailer of the equipment to refund the purchase price for such defective equipment to you in the event of a breach of this warranty, subject to the terms set out below.
- #### **Liability**
- 1.5 Except for the warranty set out in clause 1.2 above, all warranties and representations (including those expressed or implied by law) in respect of the equipment or advice relating to the equipment provided to you by RGL are excluded to the extent permitted by law.
- 1.6 Notwithstanding anything else in this manual, RGL's maximum liability to you (in the event that such liability exists) in respect of any breach of warranty, any matter set out in this manual, or for defective equipment or advice relating to the equipment provided is limited at RGL's option to:
- (a) repairing or replacing the equipment (or part of the equipment); or
 - (b) notifying the retailer of the equipment to refund the price for the equipment paid by you.
- 1.7 Notwithstanding anything else in this manual, in no event will RGL be liable, whether in contract, tort (including negligence) or otherwise:

- (a) where you have altered or modified the equipment, misused or misapplied the equipment, or the equipment has been subjected to any unusual, excessive or non-recommended use, service or handling (including as set out in this manual);
- (b) where the equipment is not transported, stored, handled or used in accordance with any directions given by RGL (or the retailer) to you (including as set out in this manual);
- (c) where the equipment:
 - (i) has been subject to neglect, accident or hireage, or the damage arises from fair wear and tear, battery damage or chemical attack;
 - (ii) has been built to a customer's specifications; or
 - (iii) has been dismantled, repaired or serviced other than by an authorised service agent of RGL;
- (d) for loss or damage caused by any factors beyond RGL's control; or
- (e) for any loss of profit or revenue, or for any special, indirect, incidental or consequential damage, loss or injury of any kind suffered by you.

1.8 Where RGL elects to repair or replace the equipment it will use reasonable endeavours to do so as soon as practicable but will not be liable for any delay in doing so.

1.9 You agree that the transactions entered into between you and the retailer (and RGL) are for the purposes of trade and that, having regard to all relevant circumstances of the transactions, it is fair and reasonable that the provisions of the Consumer Guarantees Act 1993 (NZ) do not apply to those transactions to the fullest extent permitted by law.

INSTALLATION

Unpack the spreader and check the contents.

- Spreader Unit
- Control Panel
- Owner's Manual

If you have purchased a Quicksmart and/or Quicksmart spreader frame you may also have the following.

- QS Spreader Adaptor Bracket with attachment bolts and nuts (4 sets)
- Quick Smart™ ATV Bracket with attachment clamps and hardware (4 sets)

Flatdeck Mounting.

Mark and drill four 8mm holes in the vertical surface where the machine is to be attached. Bolt the machine in place using 8mm bolts of the correct length (client supplied). The minimum recommended spinner height from the ground is 800mm.

CAUTION

For proper operation of the spreader it is not recommended that it be bolted to a horizontal surface without additional support for the chassis.

Quicksmart Attachment System.

Install the Quick Smart™ attachment kit on the ATV as detailed in the installation instructions provided in the kit.

Quicksmart Spreader Attachment frame.

Attach the QS Adaptor Bracket to the spreader using the M8x25 nuts and bolts provided.

Attach the spreader to the ATV by locking the adaptor bracket into the QS ATV bracket. Ensure that the bottom pins are correctly engaged under the latches.

WIRING

All Models

Place the Control Panel in the required position and connect the battery cable to the vehicle battery. The red wire must be connected to the positive terminal. Attach the Control Panel to the vehicle using the self-adhesive Velcro fasteners provided. The cable must be connected directly to the vehicle battery and not earthed through the vehicle chassis.

WARNING

To avoid injury ensure that the switch is in the OFF position before connecting cables.

WARNING

To avoid injury ensure that the switches are both in the off position before connecting cables.

Connect the Control Panel to the spreader. Ensure that any excess cable is stowed where it cannot be pinched or damaged.

CAUTION

To avoid damage to the spreader it is essential that the cables be correctly connected. Under no circumstances should the polarity of the wiring be reversed. The correct spinner rotation is anti-clockwise when viewed from the top.

Switch the spreader on and check that the spinner turns anti-clockwise when viewed from the top. If the spinner turns clockwise, reverse the polarity of the wiring. Your spreader is now ready to use.

SYSTEM INTERCONNECTIONS

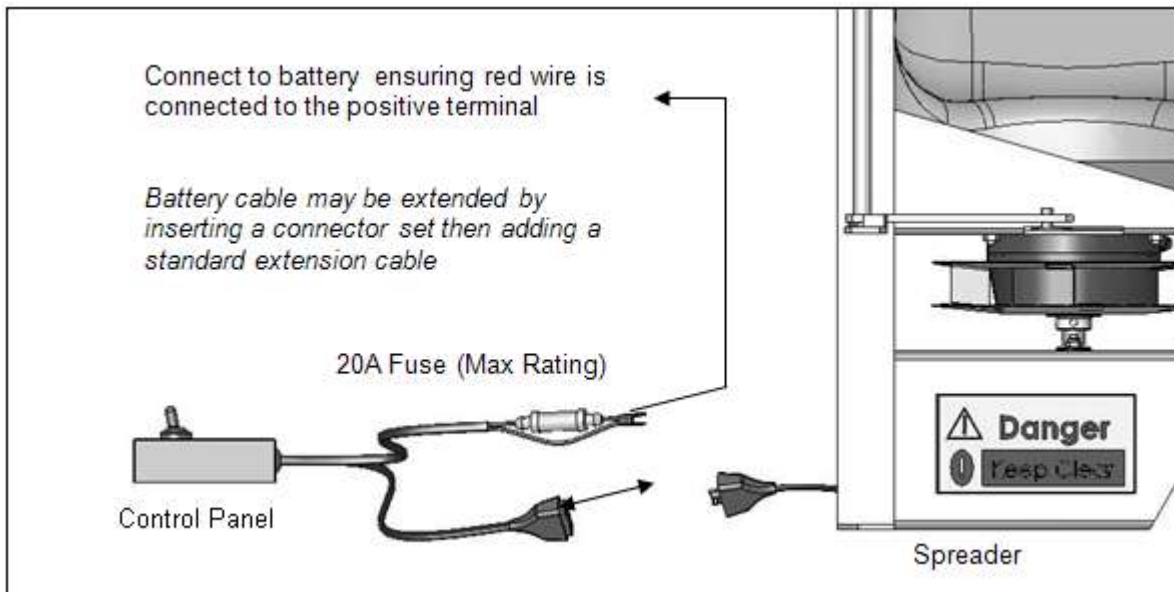

OPERATION

WARNING

For safe operation do not overload your spreader. The maximum permissible payload is 60 Kg.

WARNING

To avoid injury make sure the spinner is turned off and the shutter closed before loading the hopper.

CAUTION

To avoid damage to your spreader never use dirty product or product with stones or lumps.

The product to be spread is placed in the hopper and the lid snapped shut.

When the SPINNER switch is turned on electrical power is supplied to the shutter control switch in the control panel, and to the spinner motor. The spinner will spin up to operating speed.

WARNING

To avoid injury never turn the spreader on if there is someone standing near the spinner.

When the SHUTTER switch is turned on electrical power is supplied to the dual shutter actuators of correct polarity to open the shutter. Product will then flow from the hopper through an adjustable shutter into the delivery cone. At the base of the cone there are two delivery holes which ensure that product enters the spinning disk at the correct position to spread the product behind the spreader over 180 degrees. Only supply power to the actuators momentarily, too long and you could burn the motors out.

An agitator shaft with a removable R clip in the bottom of the hopper ensures that product flows continuously through the metering orifice. When the agitator is not required, it should be removed and stowed in the stowage hole under the hopper rim.

The manual choke is set to give the desired application rate.

For choke settings greater than 3, it is recommended that the delivery chute be rotated to expose the large aperture.

When the SHUTTER switch is turned off, electrical power is applied to the dual shutter actuators of correct polarity to close the shutter.

Only when the spinner is running will the shutter open to start delivering product to the spinner via the delivery cone orifices.

CAUTION

To avoid damage to the shutter actuators, do not hold the shutter switch in the open or closed positions for more than 1 second. The switch is designed to be momentarily pressed then allowed to spring return to centre

CALIBRATION

Make sure the shutter is in the closed position.

To calibrate your spreader place a measured amount of product in the hopper.

Set the choke to position (1-5) indicated in the Calibration Guide below.

Drive the spreader at the desired speed and open the shutter.

When the product has been exhausted, measure the area covered in square metres. It is recommended that this be done over an area where the product can be seen on the ground so that the spread width can be measured. A plastic sheet may be used.

CAUTION

For ease of calibration, the above procedure is best carried out with a large aperture. At 2 kg/ha there will be less than ten pellets per square metre. Pellets will be difficult to find at the outer limits of the spread width.

Check the application rate using the following formula:

$$\text{Rate (Kg/ha)} = \frac{\text{Product applied (Kg)} \times 10,000}{\text{Distance travelled (metres)} \times \text{spread width (metres)}}$$

Adjust either the choke or the speed of travel until the desired application rate is achieved.

NOTE

Because of variations in product characteristics, speedometer calibration and driving speed, the information in the calibration guide should be regarded as a starting point only. It is recommended that the spreader be calibrated before use.

CALIBRATION GUIDE Average Speed 12 Kph

Product	Rate (Kg/ha)	Choke Settings	Nominal Spread (metres)
Slug Pellets	2.5	1	24
Slug Pellets	8.5	2	24
Slug Pellets	15 *	2	24
Slug Pellets	17 *	3	24
Slug Pellets	18.5 *	4	24
Slug Pellets	>20 *	5	24

* Set to high rate

ADJUSTING THE DELIVERY CHUTE FOR HIGH OR LOW RATES

The spreader has been set up for slug pellets on low rate (2.5-8.5Kg/ha). When spreading products at higher rates (above choke setting 3) it is recommended that the delivery chute be adjusted to expose the high rate apertures. This is achieved by loosening the Jubilee clip, rotating the plastic delivery chute 180 degrees, and tightening the clip again. Use a screwdriver to gently rotate the plastic chute to the new position. For best performance always align the delivery chute index mark with the index mark on the underside of the hopper support plate, and ensure that the stainless steel shroud covers the unused apertures in the side the delivery chute.

CAUTION

To avoid damage to the spinner and motor ensure that there is always a 1.5 mm gap between the spinner base and the bottom of the delivery chute.

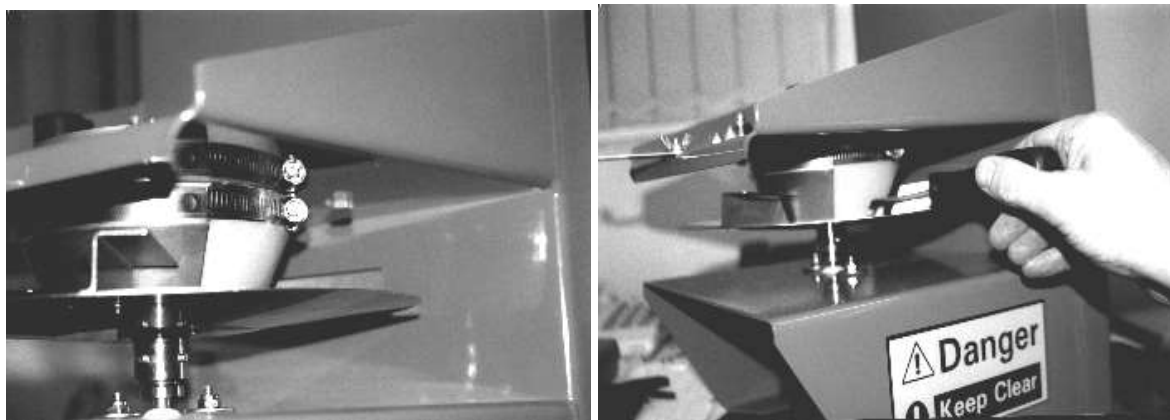

The chute/shield is shown below in the factory setting (Low Rate) on Left and high rate on right. Note that the orientation of the plastic chute has changed but the shield remains in the same place relative to the direction of travel indicated by the arrow.

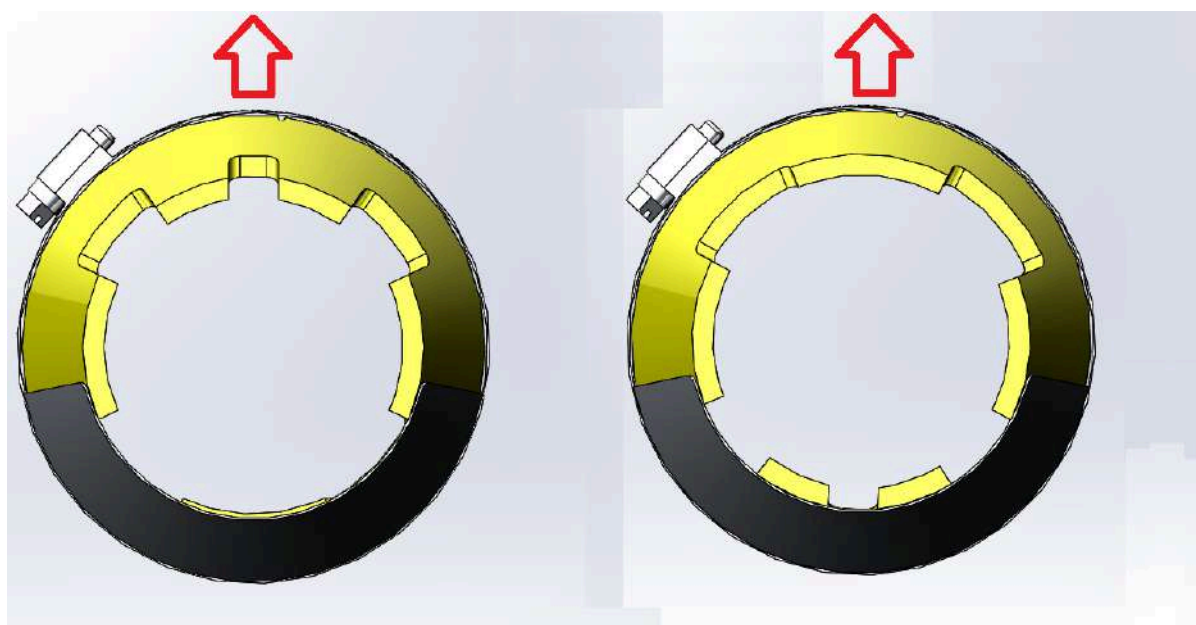

High and low rate setting as viewed from below the spreader

ADJUSTING/CENTRING THE SPREAD PATTERN

When spreading different size baits it may be necessary to adjust the centring of the spread pattern. This is achieved by loosening the Jubilee clip beneath the hopper support plate, rotating **both** the plastic delivery chute and the stainless steel shield to a new position, and tightening the clip again. **When adjusting the spread pattern the chute and shield should remain in the same orientation relative to one another.** To return the shield/chute to the factory setting simply align the chute/shield so that the cut-out is facing directly forward (in the direction of travel).

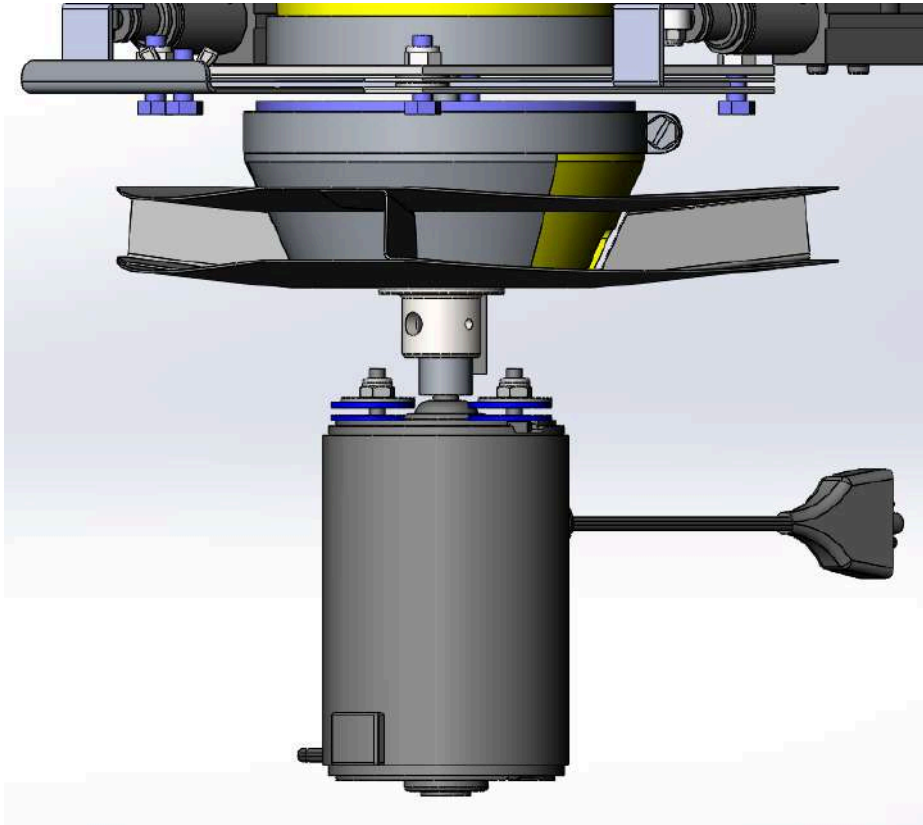

WARNING

Never adjust the delivery chute with the spreader turned on.
Never place hands or loose clothing near a revolving spinner or motor shaft.

CAUTION

To avoid damage to the spinner and motor and to ensure that the spreader performs well, ensure that there is always a 1.5 mm gap between the spinner base and the delivery chute. Too small a gap may cause interference between the spinner and chute and too large a gap may cause product to leave the chute at the wrong position and effect the accuracy of the spread pattern.

OPERATING THE SPREADER

When the spreader has been correctly calibrated, the hopper may be filled to the required level and spreading commenced.

To prevent damage to the product and inadvertently operating of the shutter, it is recommended that the spinner be turned off until area to be covered is reached.

Switch the SPINNER switch on to apply power to the machine and start the spinner.

WARNING

Some products may compact around the agitator in the hopper whilst in transit. If this occurs the motor may be overloaded when switching on for the first time. Ergo it is recommended that the spinner be checked for free movement if the spreader has been driven for any significant distance with product in the hopper and the motor switched off.

Switch the SHUTTER switch on to commence spreading product.

ROUTINE MAINTENANCE

CAUTION

The following maintenance actions are mandatory for reliable use of the spreader.

Before Use

Turn the spinner by hand to ensure that it is free to turn without interference.

Check the hopper to ensure that no debris is inside.

CAUTION

To avoid damage to your spreader never leave product in the hopper or store the spreader without cleaning it.

After each use or daily when in use

Remove all traces of product from the spreader by brushing or washing. Pay particular attention to areas where product has accumulated and built up. Remove by scraping if necessary taking care not to damage the surface finish of the spreader or its components.

If washing, do not direct high pressure water onto the actuator or motor.

After cleaning, apply water displacing fluid such as WD40 to all exposed metal parts.

Check for damaged or worn components and replace as required.

HINTS

When ordering replacement parts, always quote the spreader serial number and the part number of the required parts.

Fit the spreader to the vehicle before filling.

When replacing the fuse, always use a fuse of the correct rating. The correct fuse is a 20Amp type.

TROUBLE SHOOTING

Spinner does not turn when the SPINNER switch is turned on.

Wiring not connected	-Check connections
Fuse has blown	-Check fuse, fit correct type (20A)
Product has jammed agitator	-Empty hopper and clear
Delivery cone touching spinner	-Adjust clearance gap
Product jamming spinner	-Check shutter is closed and clear product

Spinner is running, the SHUTTER switch is on but there is no product being spread.

No product in hopper	-Turn off and fill hopper
Product is bridging across orifice	-Empty hopper and fill with fresh product
Choke is shut	-Correctly calibrate choke
Shutter control cable unplugged	-Reconnect

Product is spread unevenly

The delivery cone is too far to	-Adjust the cone to achieve even spread one side
Delivery chute apertures too large	
for application rate.	-Set delivery chute for low rate.
Product build up	-Clean product off spreader

Fuse Blows

Spinner jammed.	-Clear spinner obstruction.
Insufficient delivery chute clearance	-Reset clearance
Delivery chute overloaded	-Set delivery chute apertures for high rate.
Agitator pin jammed	-Clear agitator obstruction

WARNING

To avoid serious damage to the motor and wiring, never replace the fuse with one rated higher than 20 Amps.

Parts List

Item No.	QTY.	part no	description
1	1	1500-6100	Cable-Electrical-Loom-Slugmaster-Control Box
2	1	1980-0008	Circlip-External-8mm-DIN471-Stainless
3	1	2050-7300	Clip-R Type-Pin-2.5MM-ZP
4	1	2230-1100	Cord-Arrestor-Hinged Spreader Lid
5	3	3010-0406	Fastener-Grub Screw-Socket Head-M4x6-Stainless
6	3	3090-0512	Fastener-Machine-Screw-Pan-M5x12-Phillips-Stainless
7	2	3150-5100	Fastener-Nut-Nyloc-3/16-UNF-ZP
8	2	3170-0004	Fastener-Nut-Nyloc-M4-ZP
9	4	3170-0006	Fastener-Nut-Nyloc-M6-ZP
10	2	3170-0008	Fastener-Nut-Nyloc-M8-ZP
11	1	3200-0206	Fastener-Nut-Wing-M6-ZP
12	2	3290-0825	Fastener-Set Screw-Hex-8.8 Grade-M8x25-ZP
13	4	3310-2806	Fastener-Washer-Flat-M6x16x1.2-Grade 304-Stainless
14	2	3310-3008	Fastener-Washer-Flat-Fender-M8x32x1.5-ZP
15	1	3310-6006	Fastener-Washer-Flat-M6-ZP
16	2	3310-9210	Fastener-Washer-Flat-3/16"x7/8"x1.5-Grade 304-Stainless
17	3	3310-9210	Fastener-Washer-Flat-3/16"x7/8"x1.5-Grade 304-Stainless
18	1	3500-5900	Frame-Spreader-Slugmaster G3-PC
19	4	3700-9210	Gasket-Washer-5x25x1.6-Black-Neoprene
20	2	3880-0006	Grommet-Insulating-6x11.0mm-Rubber
21	1	5200-7000	Machined-Shaft-Spinner Drive-SlugSpreadmaster-Stainless
22	1	5240-1000	Motor-12VDC 150W-Spread/Slugmaster
23	6	5610-8000	Packer-Shutter-Slugmaster G3-Styrene
24	1	6250-3001	Plug-Electrical-2 Pin-Male-20 Amp-With Cover
25	1	6500-1000	Profiled-Adjuster-Slugmaster-G3-Profiled-Stainless
26	1	7500-2000	Rota-Hinge-LH-SM70/75
27	1	7500-2010	Rota-Hinge-RH-SM70/75
28	1	7500-2200	Rota-Hopper-Spreader-Slugmaster SM75-Yellow-MDPE
29	1	7500-2520	Rota-Lid-Hopper-SM70/75L
30	1	7500-2770	Rota-Shute-Delivery-Slugmaster G2-Yellow-MDPE
31	1	7940-7900	Shield-Delivery-Slugmaster G2/G3-Stainless
32	1	8120-4000	Spigot-Hopper-Slugmaster G3-SS
33	1	8200-8100	Spinner-Slugmaster-AU/NZ/UK current Model-Twin Disc-SS
34	1	9100-3020	Washer-Flat-Himould-9IDx25ODx2mm-Black-Plastic
35	1	4500-6380	Kit-Replacement-Actuators & Shutter-Slugmaster
36	1	6250-3000	Plug-Electrical-2 Pin-Female-20 Amp-With Cover

Notes



Slugmaster Actuator and Shutter Replacement KIT

Pt.No 4500-6380

INSTRUCTION LEAFLET

(Pt.No.2400-6380)

1. Remove the circlip, hopper, and the orifice plate, to access the current shutter.
2. Take the white packers and washers off the mounting bolts.
3. Remove the plug off the current actuators and unscrew them. Remove actuators and shutter assembly.
4. Feed new actuator wires through the grommet and refit plug – Green wires going to the middle terminal.
5. When mounting the new actuators, use supplied self-tapping screws.
6. Fit the shutter using the m4 screws and nuts, ensuring the actuators are straight when doing up screws so they don't get loaded up during operation.
7. Reassemble the unit, starting with packers and orifice plate, ensuring the correct orientation of the packers and washers as shown in figure 1.

Figure 1.

