

OWNER'S MANUAL



C-DIT 1300 SPREADER



P 0800 853 002
E info@yelo-agri.com
W www.yelo-agri.com

PARTS & SUPPORT

For parts and service support, contact your authorised Yelo store or visit our website for store locations. If you need further assistance, we are only a phone call or email away. Parts list included.



SAFETY PRECAUTIONS

CDIT1300 LINKAGE

AN IMPORTANT MESSAGE FOR OWNERS & OPERATORS OF RGL ATTACHMENTS/ACCESSORIES

Be warned of the dangers of loading your tractor or other vehicle in excess of its carrying capacity. It is important to understand that any loads or attachments whether fastened to or placed on a vehicle or tractor will alter the stability or handling characteristics of that vehicle or tractor. Spreaders or other equipment must be filled only to a level where the gross weight is within the load limit of the tractor or other vehicle.

Safety is a primary concern in the design, manufacture, sale, and use of spreaders and other equipment. As manufacturers of spreaders and other equipment we want to confirm to you, our customers, our concern for safety. We take this opportunity to remind you about the simple, basic and common sense rules of safety when using spreaders and other equipment. Failure to follow these rules can result in severe injury or death to operators and bystanders.

It is essential that everyone involved in the assembly, operation, transport, maintenance and storage of this equipment be aware, concerned, prudent and properly trained in safety.

This also applies to equipment that is loaned or rented to someone who has not read the owner's manual and is not familiar with the operation of application equipment.

- NEVER EXCEED THE LOAD LIMIT CAPACITY OF THE ATV OR OTHER VEHICLE.
- ALL TRACTOR AND TRAILED EQUIPMENT TYRES SHOULD BE INFLATED TO MANUFACTURERS RECOMMENDED OPERATING PRESSURES.
- PLEASE NOTE THAT FILLING THE SPREADER OR OTHER EQUIPMENT COMPLETELY AND OR THE ATTACHMENT OF ADDITIONAL EQUIPMENT TO THE TRACTOR MAY EXCEED THE TRACTOR'S MAXIMUM LOAD CAPACITY AND IT IS NOT RECOMMENDED TO EXCEED MANUFACTURERS GUIDELINES
- CARGO SHOULD BE PROPERLY DISTRIBUTED AND SECURELY ATTACHED.
- REDUCE SPEED WHEN CARRYING CARGO OR PULLING A TRAILER OR TRAILED APPLICATION EQUIPMENT AND ALLOW GREATER DISTANCE FOR BRAKING.
- NEVER ALLOW ANYONE TO RIDE ON YOUR SPREADER OR OTHER EQUIPMENT.
- ALWAYS FOLLOW THE INSTRUCTIONS IN THE OWNER'S VEHICLE MANUAL FOR CARRYING CARGO OR PULLING A TRAILER.
- PROPER MAINTENANCE IN LINE WITH MANUFACTURER'S RECOMMENDED MAINTENANCE PROCEDURES IS ESSENTIAL.
- BEFORE APPLYING CHEMICALS, READ THE LABEL OF THE CHEMICAL MANUFACTURER OR SUPPLIER FOR PERSONAL PROTECTIVE EQUIPMENT AND OPERATE AS RECOMMENDED.
- THE SAFETY OF ALL CHEMICALS USED IN AGRICULTURE IS UNDER THE JURISDICTION OF A GOVERNMENT AGENCY, IE N.Z. MINISTRY FOR THE ENVIRONMENT; USA ENVIRONMENTAL PROTECTION AGENCY. FURTHER LOCAL GOVERNMENT OR STATE LAWS MAY APPLY.

SAFETY PRECAUTIONS

Before attempting to install or operate the equipment, read and understand the manual thoroughly. Failure to comply with this instruction constitutes improper use and will invalidate the warranty.

Throughout this manual there are highlighted text boxes containing warnings, cautions and notes.

Warnings are mandatory instructions to prevent serious injury or permanent damage.

Cautions are advisory instructions to ensure reliable operation of the equipment.

Notes are for convenient operation.

- **Do not overload your spreader. The maximum permissible payload is 1000 Kg.**
- Never use dirty product or product with stones or lumps.
- Ensure that your carrying vehicle is adequate for the task.
- If using the spreader over hilly terrain the payload should be reduced to ensure that the spreader stability is not compromised.
- Never allow anyone to ride on or in the spreader.
- Keep the spreader in good condition. Cleanliness and maintenance are essential for safe and trouble free operation.
- Never leave product in the hopper or store the spreader without cleaning it.
- This spreader is not suitable for spreading magnesium oxide or other fine powders.

WARNING/CAUTION

PTO shaft length may be need to be trimmed depending on tractor.

The shaft length should be determined with the linkages adjusted appropriately for the sprayer/spreader (i.e. level).

Read PTO Shaft instructions (attached to shaft) before fitting/operating unit, failure to do so could cause damage to the unit attached.

Always exercise caution when working around PTO shafts. Never work in the vicinity of a PTO shaft that has its drive engaged.

CDIT1300 LINKAGE

OWNER'S MANUAL

(Pt.No.2400-5620)

Contents

SAFETY PRECAUTIONS.....	3
INTRODUCTION	5
DESCRIPTION	5
OPERATION	7
OPERATING THE SPREADER	8
MAINTENANCE	10
HINTS	10
REMOTE CONTROL SPREADER OPERATIONS MANUAL.....	18
PARTS DIAGRAM.....	35
PARTS LIST	36
PARTS DIAGRAM – TRAILER KIT	41

NOTE

Operation of the CDIT1300 spreader on tractors with dual wheels may affect the spread pattern

INTRODUCTION

Congratulations. You have just purchased an advanced spreader from RGL. RGL is committed to providing you, the farmer, with quality applying systems.

DESCRIPTION

The Yelo **CDIT1300** is a 3PL spreader, with optional trailer kit, designed for application of pelleted fertilisers and other products such as grass seed. The uniquely designed 1300-litre non-corrosive polyethylene hopper is specially profiled for good product flow and ease of filling. The convenient vinyl cover is easy to remove, install and store if not required. Twin high-quality stainless steel agitator and shutters ensure even flow of product to the spinners. A unique spinner design ensures wide, even spread of products over 180 degrees (Urea). The heavy duty frame is fully galvanised. The drive train uses high quality steel and heavy-duty gearbox's for maximum durability. The CDIT1300 features an in-cab controller which maintains the selected application rate.

Specifications

(Specifications subject to change without notice)

Dry Weight	220 Kg (3PL unit)
Dimensions	W2100mm, H1600mm, L1450mm
Capacity	1300litre (1000Kg Urea)
Drive	PTO
Agitator	Mechanical arm, stainless steel
Spinner	Stainless steel with five-position adjustable vanes
Hopper	Non-corrosive polyethylene, ergonomically designed for ease of filling and inspection
Hopper cover	Polyethylene plastic
Frame	Galvanised steel
Gearbox	Heavy duty with double sealed bearings
Gearbox oil	400ml SAE30 (each gearbox)
Axle grease	General Purpose
Application Rate	150Kg per hectare @ 10 kph (nominal, Urea)
Spread width	24M (nominal, Urea @ 15 Kph)
Towing speed	15 Kph (Maximum recommended)
Wheels (Trailed unit Only)	10.0/80-12 Agricultural tyres (not suitable for highway use)
Tyre Pressure (Trailed unit Only)	15PSI (100Kpa)

Order Information

CDIT 1300 3PL	P/N 3014
CDIT 1300 Trailer kit	P/N 3015

WARRANTY

Use of the equipment

- 1.1 You must satisfy yourself as to the suitability of the equipment for your intended use(s) of the equipment.

Your relationship with the retailer

- 1.2 Where you consider you have a warranty claim (or any other claim) in relation to the equipment, you must contact the retailer who sold you the equipment, not RGL directly. The retailer is responsible for liaising with RGL in respect of your claim.

Warranty

- 1.3 RGL warrants to the original purchaser that the equipment is sold free from defects in materials and workmanship for a period of 12 months from date of first retail sale subject to the terms set out below.

- 1.4 RGL will at its option repair or replace the defective equipment (or part of the equipment) or notify the retailer of the equipment to refund the purchase price for such defective equipment to you in the event of a breach of this warranty, subject to the terms set out below.

Liability

- 1.5 Except for the warranty set out in clause 1.2 above, all warranties and representations (including those expressed or implied by law) in respect of the equipment or advice relating to the equipment provided to you by RGL are excluded to the extent permitted by law.
- 1.6 Notwithstanding anything else in this manual, RGL's maximum liability to you (in the event that such liability exists) in respect of any breach of warranty, any matter set out in this manual, or for defective equipment or advice relating to the equipment provided is limited at RGL's option to:
- (a) repairing or replacing the equipment (or part of the equipment); or
 - (b) notifying the retailer of the equipment to refund the price for the equipment paid by you.
- 1.7 Notwithstanding anything else in this manual, in no event will RGL be liable, whether in contract, tort (including negligence) or otherwise:
- (a) where you have altered or modified the equipment, misused or misapplied the equipment, or the equipment has been subjected to any unusual, excessive or non-recommended use, service or handling (including as set out in this manual);
 - (b) where the equipment is not transported, stored, handled or used in accordance with any directions given by RGL (or the retailer) to you (including as set out in this manual);
 - (c) where the equipment:
 - (i) has been subject to neglect, accident or hireage, or the damage arises from fair wear and tear, battery damage or chemical attack;
 - (ii) has been built to a customer's specifications; or
 - (iii) has been dismantled, repaired or serviced other than by an authorised service agent of RGL;
 - (d) for loss or damage caused by any factors beyond RGL's control; or
 - (e) for any loss of profit or revenue, or for any special, indirect, incidental or consequential damage, loss or injury of any kind suffered by you.
- 1.8 Where RGL elects to repair or replace the equipment it will use reasonable endeavours to do so as soon as practicable but will not be liable for any delay in doing so.
- 1.9 You agree that the transactions entered into between you and the retailer (and RGL) are for the purposes of trade and that, having regard to all relevant circumstances of the transactions, it is fair and reasonable that the provisions of the Consumer Guarantees Act 1993 (NZ) do not apply to those transactions to the fullest extent permitted by law.

OPERATION

The product to be spread is placed in the hopper. The mechanical action of the spinners and agitators is driven from the PTO output on the tractor (at 540RPM). The shutter positions are controlled by a 12v linear actuator. The rate is set by selecting the desired gate setting via a remote control box (settings go from 1-8). For rate setting to suit your material and speed, please consult the YELO REMOTE SPREADER CONTROL manual supplied with your spreader.

An extension of the spinner boss is connected to a stainless steel agitator arm inside the bottom of the hopper. The agitator ensures that product flows continuously out of the hopper to the spinning disk.

A delivery chute on the bottom of the hopper ensures that product is delivered to the correct spot of the disk so that the deflectors distribute the product over a wide angle behind and to each side of the spreader.

The optimum working height for the spreader is with the tips of the spinner vanes 800mm above the ground.

The polyethylene cover can be fitted to prevent rain and debris from entering the hopper.

NOTE

For operation of the smart controller please see the *Smart Controller – Assembly and Operation Manual*
(included in your console kit)

OPERATING THE SPREADER

When the spreader has been correctly set up on the tractor's three point linkage, the hopper may be filled to the required level and spreading commenced.

To reduce agitator damage to product and to ensure that product is not forced past the agitator shaft when towing the spreader to the area to be treated, the PTO drive to the gearbox should be disabled during transportation or during periods when the shutter remains closed for some time.

WARNING

To prevent damage to the spreader do not tow the spreader at speeds in excess of 15 Kph.

Adjusting the Spread Pattern

NOTE: The instructions below apply to the clockwise (viewed from above) rotating spinner which is the left most spinner when the unit is viewed from behind the tractor. The directions noted will be opposite for the counter-clockwise rotating spinner.

The spreader has been set up for spreading pelletised fertiliser. When spreading lighter products or products with a high powder content it may be necessary to adjust the deflectors on the spinner to centralise the spread pattern. To shift the pattern to the centre the inside end of the vanes should be moved anti-clockwise. These positions are highlighted in the following diagram.

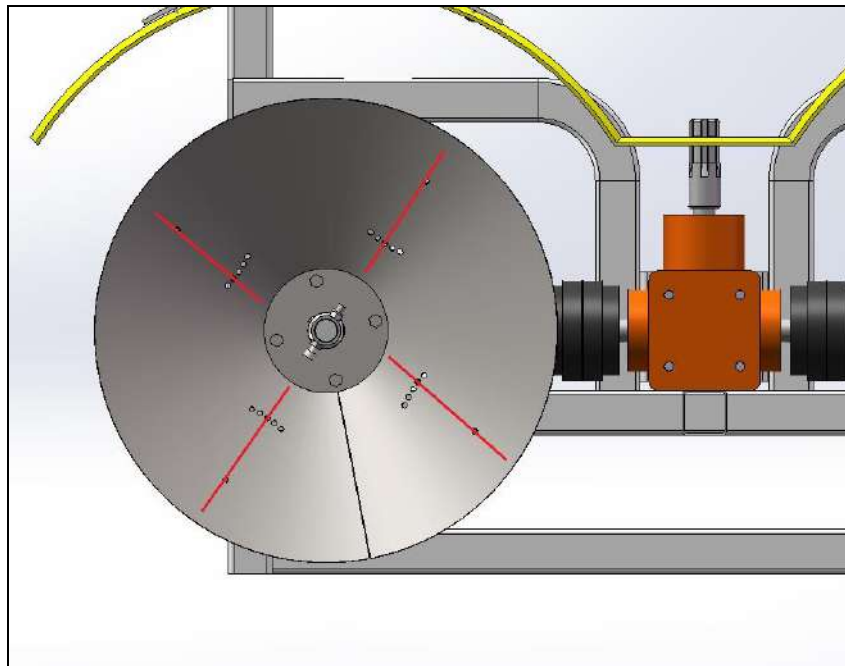

To spread to one side only

Disconnect the desired linkage at the pivot end by removing the r-clip and stowing the linkage in the tab located on the main frame as shown below. When spreading in this configuration you must adjust the console into one sided mode. For instructions on this refer to the console assembly and operation manual.



WARNING

To prevent damage to the spinner and shrouds, do not operate the spreader unless the screws are tight. Periodically check the clearance between the spinner and the plastic shroud.

Fitting the Cover

To fit the rain cover to the hopper, slide the lid over the hopper, locating it centrally on the hopper. Secure the lid by pulling the bungee cord on the cover down and hitching it on the black catches on the sides of the hopper.

MAINTENANCE

The following maintenance actions are mandatory for reliable use of the spreader.

Before Use

Check the hopper to ensure that no debris is inside.

If the spreader has not been used for some time, grease the moving parts of the frame.

Check the clearance between the plastic shrouds and the stainless steel spinners.

Check that the drive system is operating freely and smoothly.

Check the gearboxes for leaks. If leaks are detected it will be necessary to drain and replenish the gearbox with 400ml of SAE 30 oil.

CAUTION

To replenish the gearbox oil, the gearbox(s) must be removed from the spreader (as the oil filler cap is located on the underside of the gearbox). It is recommended that this be carried out by an authorised Yelo agent.

CAUTION

Always exercise caution when working around PTO shafts. Never work in the vicinity of a PTO shaft that has its drive engaged.

After Each Use or Daily When In Use

Remove all traces of product from the spreader by brushing or washing. Pay particular attention to areas where product has accumulated and built up. Remove by scraping if necessary taking care not to damage the surface finish of the spreader or its components.

If washing, do not direct high-pressure water onto the gearboxes, actuator or control box on the spreader.

Check for damaged or worn components and replace as required.

HINTS

To remove the agitator from the hopper, remove the bolt, which attaches the agitator shaft to the spinner flange assembly then withdraw the agitator from inside the hopper.

When ordering replacement parts always quote the Part Number of the required part.



REMOTE SPREADER CONTROL OPERATION MANUAL

Version: 2400-5580 – 3

This section contains:

- **Introduction**
- **Important Safety Warning**
- **Important Safety Information**
- **Table of Contents**
- **Warranty**
- **Disclaimer. Limit of Liability**
- **Unpacking your Remote Control**

DANGER!



**ACTUATOR WILL AUTOMATICALLY RETRACT ON CONSOLE STARTUP
NEVER PUT HANDS/FINGERS NEAR MOVING PARTS OF UNIT**

Introduction

Congratulations on your purchase of a **Yelo Remote spreader control unit**. We are confident that your control unit will perform for many years as long as sensible equipment maintenance/operational practices are followed. We have endeavoured to make the unit as robust and functional as possible, but please remember that like any piece of precision electronic equipment, its performance parameters need to be respected.

We thank you for making this investment and assure you of our attention at all times.

IMPORTANT SAFETY WARNING

The Yelo Remote Control is designed to be used with the Yelo CDIT spreaders, either towed behind an agricultural vehicle or mounted to a three point linkage. Operators should note that like any piece of trailed or mounted agricultural equipment, **THE SPREADER WILL AFFECT THE STABILITY AND HANDLING CHARACTERISTICS OF THE TOWING VEHICLE. FAILURE TO TAKE ACCOUNT OF THIS AND EXERCISE CAUTION WHEN OPERATING THE DEVICE MAY RESULT IN INJURY, OR IN EXTREME CIRCUMSTANCES, DEATH TO THE OPERATOR OR BYSTANDERS. OPERATORS ARE REMINDED THAT GROUND CONDITIONS COULD BE SLIPPERY AND THAT UNDULATIONS IN TERRAIN MAY BE CONCEALED BY GRASS OR OTHER VEGETATION.**

OPERATORS ARE FURTHER REMINDED NEVER TO EXCEED THE MANUFACTURERS RECOMMENDED LOADING LIMITS FOR THE TOWING VEHICLE. C-Dax accepts no liability whatsoever for damage or injuries sustained while using the remote controller.

IMPORTANT SAFETY INFORMATION

Be warned of the dangers of loading your ATV or other vehicle in excess of its carrying capacity. It is important to understand that any loads or attachments whether fastened to, or placed on a vehicle or an ATV, will alter the stability or handling characteristics of that vehicle or ATV. Spreaders or other equipment must be filled only to a level where the gross weight is within the load limit of the ATV or other vehicle.

Safety is a primary concern in the design, manufacture, sale, and use of spreaders and other equipment. As manufacturers of spreaders and other equipment we want to confirm to you, our customers, our concern for safety. We take this opportunity to remind you about the simple, basic and common sense rules of safety when using spreaders and other equipment. Failure to follow these rules can result in severe injury or death to operators and bystanders.

It is essential that everyone involved in the assembly, operation, transport, maintenance and storage of this equipment be aware, concerned, prudent and properly trained in safety.

This also applies to equipment that is loaned or rented to someone who has not read the owner's manual and is not familiar with the operation of the equipment.

- **NEVER EXCEED THE LOAD LIMIT CAPACITY OF THE ATV OR OTHER VEHICLE.**
- **ALL ATV AND TRAILED EQUIPMENT TYRES SHOULD BE INFLATED TO MANUFACTURERS RECOMMENDED OPERATING PRESSURES.**
- **PLEASE NOTE THAT FILLING THE SPREADERS OR OTHER EQUIPMENT COMPLETELY AND OR THE ATTACHMENT OF ADDITIONAL EQUIPMENT TO THE ATV MAY EXCEED THE ATV'S MAXIMUM LOAD/S CAPACITY AND IT IS NOT RECOMMENDED TO EXCEED MANUFACTURERS GUIDELINES**
- **LOAD/S SHOULD BE PROPERLY DISTRIBUTED AND SECURELY ATTACHED.**
- **REDUCE SPEED WHEN CARRYING LOAD/S OR PULLING A TRAILER OR TRAILED APPLICATION EQUIPMENT AND ALLOW GREATER DISTANCE FOR BRAKING.**
- **NEVER ALLOW ANYONE TO RIDE ON YOUR SPRAYER OR OTHER EQUIPMENT.**
- **ALWAYS FOLLOW THE INSTRUCTIONS IN THE VEHICLE OWNERS MANUAL FOR CARRYING LOADS OR PULLING A TRAILER.**
- **PROPER MAINTENANCE IN LINE WITH THE MANUFACTURER'S RECOMMENDED MAINTENANCE PROCEDURES IS ESSENTIAL.**
- **BEFORE APPLYING CHEMICALS, READ THE LABEL OF THE CHEMICAL MANUFACTURER OR SUPPLIER FOR THEIR PERSONAL PROTECTIVE EQUIPMENT INSTRUCTIONS AND OPERATE AS RECOMMENDED.**
- **THE SAFETY OF ALL CHEMICALS USED IN AGRICULTURE IS UNDER THE JURISDICTION OF A GOVERNMENT AGENCY, EG. N.Z. MINISTRY FOR THE ENVIRONMENT; USA ENVIRONMENTAL PROTECTION AGENCY ETC. FURTHER LOCAL GOVERNMENT OR STATE LAWS MAY APPLY.**

TABLE OF CONTENTS

Introduction	1
Warranty	4
Assembly & Setup	7
The Remote Control	8
Assembly & Setup – Remote Control	9
SPREAD	11
Understanding the remote control	12
How the spreading process works	13
Spreader Application Rates	14
PARTS	18
Exploded Parts Diagram	19
TROUBLESHOOTING	20
Troubleshooting Tips	21

Warranty

1 **WARRANTY AND LIABILITY**

Use of the equipment

- 1.1 You must satisfy yourself as to the suitability of the equipment for your intended use(s) of the equipment.

Your relationship with the retailer

- 1.2 Where you consider you have a warranty claim (or any other claim) in relation to the equipment, you must contact the retailer who sold you the equipment, not RGL directly. The retailer is responsible for liaising with RGL in respect of your claim.

Warranty

- 1.3 RGL warrants to the original purchaser that the equipment is sold free from defects in materials and workmanship for a period of 12 months from date of first retail sale subject to the terms set out below.

- 1.4 RGL will at its option repair or replace the defective equipment (or part of the equipment) or notify the retailer of the equipment to refund the purchase price for such defective equipment to you in the event of a breach of this warranty, subject to the terms set out below.

Liability

- 1.5 Except for the warranty set out in clause 1.2 above, all warranties and representations (including those expressed or implied by law) in respect of the equipment or advice relating to the equipment provided to you by RGL are excluded to the extent permitted by law.

- 1.6 Notwithstanding anything else in this manual, RGL's maximum liability to you (in the event that such liability exists) in respect of any breach of warranty, any matter set out in this manual, or for defective equipment or advice relating to the equipment provided is limited at RGL's option to:

- (a) repairing or replacing the equipment (or part of the equipment); or
 - (b) notifying the retailer of the equipment to refund the price for the equipment paid by you.
- 1.7 Notwithstanding anything else in this manual, in no event will RGL be liable, whether in contract, tort (including negligence) or otherwise:
- (a) where you have altered or modified the equipment, misused or misapplied the equipment, or the equipment has been subjected to any unusual, excessive or non-recommended use, service or handling (including as set out in this manual);

- (b) where the equipment is not transported, stored, handled or used in accordance with any directions given by RGL (or the retailer) to you (including as set out in this manual);
 - (c) where the equipment:
 - (i) has been subject to neglect, accident or hireage, or the damage arises from fair wear and tear, battery damage or chemical attack;
 - (ii) has been built to a customer's specifications; or
 - (iii) has been dismantled, repaired or serviced other than by an authorised service agent of RGL;
 - (d) for loss or damage caused by any factors beyond RGL's control; or
 - (e) for any loss of profit or revenue, or for any special, indirect, incidental or consequential damage, loss or injury of any kind suffered by you.
- 1.8 Where RGL elects to repair or replace the equipment it will use reasonable endeavours to do so as soon as practicable but will not be liable for any delay in doing so.
- 1.9 You agree that the transactions entered into between you and the retailer (and RGL) are for the purposes of trade and that, having regard to all relevant circumstances of the transactions, it is fair and reasonable that the provisions of the Consumer Guarantees Act 1993 (NZ) do not apply to those transactions to the fullest extent permitted by law.

Unpacking Your Console

When unpacked, you should have the following components:



Controller



Power Cable



Data Cable



Operation & Assembly Manual



Battery Connecting Cable

Should any of the above items be missing or damaged, please contact our Customer Service Department for replacement.

RGL
105 Kaimanawa Street, Kelvin Grove,
Palmerston North 4414
Ph: 06 2802468
E-Mail: info@redbackglobal.com.
www.redbackglobal.com

This section contains:

- Remote Control mounting
- Assembly & Setup – Remote Control

The Remote Control

This is normally mounted in a convenient position on the front carrier of the ATV/RTV or in the cab of a tractor. It is connected by cable to the vehicles 12v battery and also by a data cable to the spreader. Care should be taken when mounting the controller to ensure the greatest protection from the ingress of water.



Important:

If the unit is connected to a trailed spreader do not operate the controller while stationary as there is a risk that the two sides of the clutch mechanism will clash instead of engaging

NOTE: Controllers are factory programmed to the spreader type with which they were sold. If the controller is used with another type of spreader the rates will not match those in the table.

Assembly & Setup – Remote Control

Step One

- Locate a convenient flat surface of sufficient size to fit the controller to.
- Separate the “loop” Velcro from the back of the controller and push the adhesive Velcro firmly against surface.

Step Two

- Carefully route the power and data cable from the controller to the back of the ATV/RTV/Tractor.
- Take care to avoid “pinch points” and hot surfaces such as the exhaust system.

Step Three

- Connect the 4 pin female power cable to underside of controller.
- Connect other end of power cable to battery connector cable and run power cable to ATV battery housing.
- Connect the 7 pin male end of the 4m data cable to underside of indicator controller.
- Removal of the controller is the reverse process.

Note:

While every effort has been made to protect the controller from the ingress of water, users are advised to remove the controller from the ATV/RTV before washing down the vehicle. No hard water should be directed near the controller at any time.

Important:

- **Make sure you attach the end of the cable to the rear carrier so that it is on the opposite side of the ATV from the exhaust pipe.**
- **The controller consumes a small amount of power when not in use. It is therefore recommended that the power cable be disconnected when not spreading.**
- **Never replace the fuse in the controller power cable with a larger value than the one supplied **(5Amp)****

Note:

The battery connector cable is supplied for connection to batteries that do not already have a Yelo battery connector cable fitted. If already fitted, connect the blue / white power cable directly to it.

The path to run the cables to the battery and rear carrier is up to the installer but should be chosen to protect the cables and so as not to obstruct the operator.

The rear end of the black cable should be attached so that just the plug and 50mm of cable hang down for attachment to the trailed implement cable. Coil excess cable under seat or tie under rear carrier out of the way.

This section contains:

- **Understanding the controller**
- **How the spreading process works**
- **Application Rate Tables**

Understanding the remote control

In preparation for use of your CDIT400, CDIT650 or CDIT1300 Remote Control Spreader you need to ensure that you have attended to the following:

- Made the initial hardware setups for the spreader
- Made the initial controller setup (mount controller, route cables etc.)
- Referred to the application rate table to select the desired settings for your controller / spreader combination



How the spreading process works

The steps below outline the overall process for spreading operations.

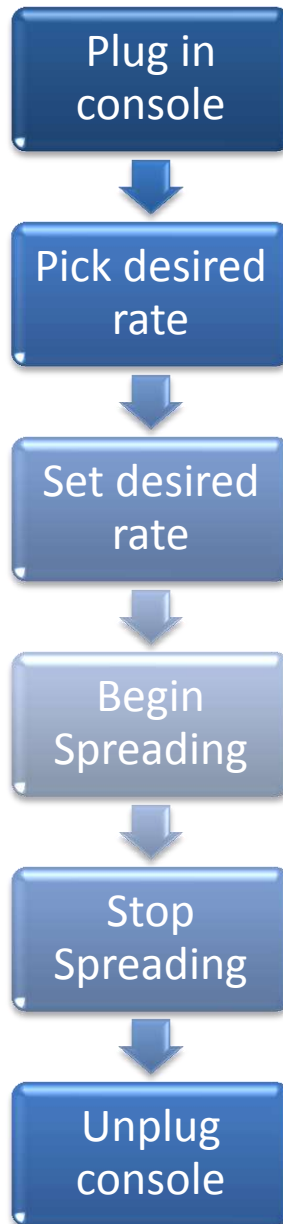

Refer to the application rate tables on **pages 14-17** of this manual.

Turn the rotary dial to the setting from the application rate lookup table.

Toggle the ON/OFF switch to the ON position to open the shutter. Drive around paddock at the recommended bout width and spread product.

Toggle the ON/OFF switch to the OFF position to close the shutter.

Unplug the controller if spreading activities are finished.

Spreader Application Rates

NOTE

Because of variations in product characteristics, speedometer calibration and driving speed, the **information in the calibration guide should be regarded as a starting point only**. It is recommended that the spreader be calibrated before use.

Application rates are chosen by using the tables on the next three pages of this manual. The diagram below explains the process of selecting an application rate.

1. Select the correct table for the spreader which you are using
2. Select the material which you are spreading
3. Use the matrix to find the desired application rate
4. Drive the speed and bout width given in the table

NOTE: Always drive to the conditions. Never exceed speeds which are safe for the conditions/equipment with which you are operating

In the below example we have chosen the spreader we are using (CDIT400), the material we are spreading (UREA) and the target application rate of 50Kg/Ha.

To achieve this application rate we would now use setting 4 on the controller and drive 15m bout widths at a speed of 10km/h.

If we want to spread at a higher speed (**and conditions allow it to be done safely**) we simply move to the next speed column in the table and select the closest application rate, in this case either 55Kg/Ha at 12km/h or 45Kg/Ha at 14Km/h on setting 5

CDIT400 MATERIAL APPLICATION RATE (Kg/Ha)												
	DAP			Urea			Super			Seed		
Speed	10km/h	12km/h	14km/h	10km/h	12km/h	14km/h	10km/h	12km/h	14km/h	10km/hr	12km/h	14km/h
Bout Width	15m			15m			12m			6m		
0	Closed											
1	8	7	6	5	4	3	7	6	5	N/A	N/A	N/A
2	25	20	15	20	17	15	30	25	23	15	13	11
3	45	35	30	35	30	25	55	50	40	35	25	20
4	55	50	45	50	40	35	80	70	60	50	40	35
5	80	70	60	65	55	45	110	90	75	65	55	50
6	100	85	70	80	65	55	135	110	95	85	70	60
7	120	100	85	90	75	65	160	130	115	100	85	75
8	145	120	105	115	95	80	195	165	140	130	105	90

CDIT400 MATERIAL APPLICATION RATE (Kg/Ha)

	DAP			Urea			Super			Seed		
<u>Speed</u>	10km/h	12km/h	14km/h	10km/h	12km/h	14km/h	10km/h	12km/h	14km/h	10km/hr	12km/h	14km/h
<u>Bout Width</u>	15m			15m			12m			6m		
0	Closed											
1	8	7	6	6	5	4	7	6	5	N/A	N/A	N/A
2	25	20	15	20	17	15	30	25	23	15	13	11
3	45	35	30	35	30	25	55	50	40	35	25	20
4	65	55	45	50	40	35	80	70	60	50	40	35
5	80	70	60	65	55	45	110	90	75	65	55	50
6	100	85	70	80	65	55	135	110	95	85	70	60
7	120	100	85	90	75	65	160	130	115	100	85	75
8	145	120	105	115	95	80	195	165	140	130	105	90

CDIT650 MATERIAL APPLICATION RATE (Kg/Ha)

	DAP			Urea			Super			Seed		
<u>Speed</u>	8km/h	10km/h	12km/h	8km/h	10km/h	12km/h	8km/h	10km/h	12km/h	8km/h	10km/h	12km/h
<u>Bout Width</u>	18m			18m			14m			6m		
0	Closed											
1	30	25	20	20	15	15	60	45	40	35	30	20
2	40	35	30	30	25	20	85	65	55	45	40	30
3	55	45	35	40	35	30	110	85	70	60	45	40
4	70	55	45	55	40	35	130	105	90	70	55	50
5	85	65	55	65	50	40	155	125	105	80	65	55
6	100	80	65	75	60	50	180	145	120	95	75	65
7	110	90	75	85	65	55	205	165	140	105	85	70
8	125	100	85	95	75	60	230	185	155	120	95	80

CDIT1300 MATERIAL APPLICATION RATE (Kg/Ha)

	DAP			Urea			Super			Seed		
<u>Speed</u>	8km/h	10km/h	12km/h	8km/h	10km/h	12km/h	8km/h	10km/h	12km/h	8km/h	10km/h	12km/h
<u>Bout Width</u>	24m			24m			22m			10m		
0	Closed											
1	60	45	40	40	35	25	90	70	60	45	35	30
2	80	65	55	60	50	40	120	95	80	65	50	45
3	100	80	70	80	65	55	150	120	100	85	65	55
4	125	100	80	100	80	65	180	145	120	105	85	70
5	145	115	95	115	95	80	215	170	140	125	100	80
6	165	135	110	135	110	90	245	195	165	145	115	95
7	190	150	125	155	125	105	275	220	185	165	130	110
8	220	175	145	185	145	125	325	260	215	195	155	130

This section contains:

- Exploded parts diagram
- Parts list

Exploded Parts Diagram

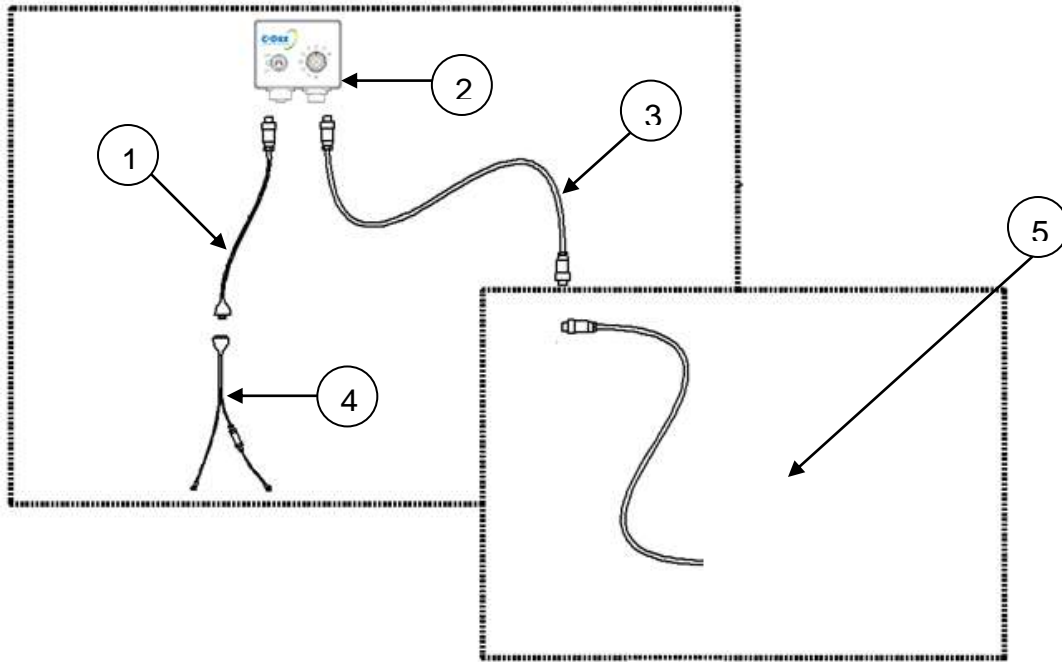

Item Number	Part Number	Description
1	1500-7150	Cable-Electrical-Loom-CDIT Remote Control to Battery Cable
2	2220-0400	C-DIT In-Cab Remote Control
3	1500-7200	Cable-Electrical-Data-Pasturemeter/Spreader Extension-7 Core-4M
4	1500-3700	Cable-Electrical-Loom-Battery Feed-2.2M
5	3004/3014/3017	Spreader (not shown) Connected to Remote Control

This section contains:

- **Trouble Shooting Tips**

Troubleshooting Tips

Symptom	Possible causes	Probable solution
Actuator Will Not Drive	Disconnected Data Cable	Check connections between controller and data cable and spreader and data cable.
	Damaged Data Cable	Inspect data cable and plugs for damage/corrosion. Contact RGL for replacement cables.
	Switchbox incorrectly connected	The remote control is designed to be connected directly to the linear actuator on the spreader. It should not be connected through another switchbox (grey box) on the spreader. Disconnect the extra grey box from the system and connect the output from the remote control directly to the black linear actuator cable.
	Damaged Actuator	Contact RGL.
Controller will not operate at all	Blown Fuse	Replace fuse with correct value (5A). If this is occurring regularly check that the power connections are properly insulated.
	Disconnected Power Cable	Check connections between controller, power cable and battery.
	Controller fault	Contact RGL.
Application rate is incorrect	Incorrect controller setting	Consult application table on page 14. Select the correct material and desired rate. Switch controller to the corresponding dial setting.
		If the desired material is not in the table, choose a material that is similar in particle size and density.
	Miss-matched controller	Controllers are factory programmed to the spreader type with which they were sold. If the controller is used with another type of spreader the rates will not match those in the table.
	Aperture blockage	After disengaging drive to the spinner and removing power to the controller check the spreader aperture for blockages. Check material being spread is granular and free flowing. Products such as lime are likely to cause bridging.
	Incorrect bout width	Make sure you drive at the correct bout width as in the application table on page 14.
	Incorrect speed	Make sure you drive at the correct speed as in the application table on page 14 NOTE: Never drive at speed in excess of what is safe for conditions.

PARTS DIAGRAM
 (Units manufactured prior to May 2016)

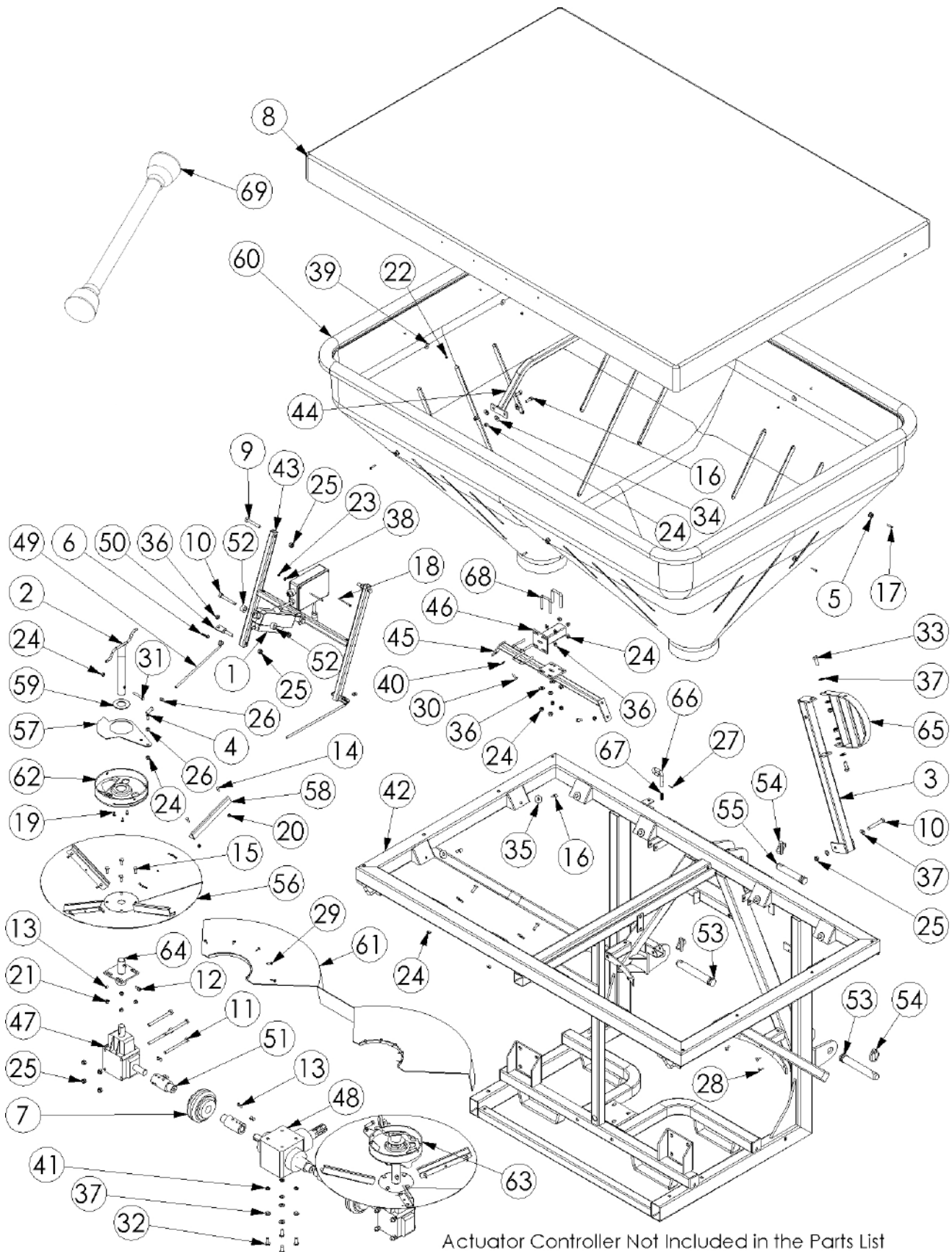

Actuator Controller Not Included in the Parts List

Actuator Controller Not Included in the Parts List

PARTS LIST
(Units manufactured prior to May 2016)

Item No.	QTY.	e9 part no	e9 description
1	1	1010-2391	Actuator-Electrical-Smart Control-With Plug fitted
2	2	1036-8240	Agitator-Spreader-CDIT300/400-In-Ex300/400-SS
3	1	1072-7500	Arm-Step-Goldline-800/1000L-GL
4	2	1110-2308	Ball-End-Internal Thread-M8-Zinc Plated
5	8	1455-8800	Button-Ute Cover-Bungy Cord Retain-Black-Plastic
6	2	2050-7350	Clip-R Type-Pin-2mm-ZP
7	2	2233-2630	Coupling-Drive-Fenaflex-Set
8	1	2250-4110	Cover-Hopper-Blue Fabric-Spreader CDIT1300
9	3	2840-1065	Fastener-Bolt&Nut-Hex-8.8 Grade-M10x65-ZP
10	2	2840-1075	Fastener-Bolt&Nut-Hex-8.8 Grade-M10x75-ZP
11	8	2840-1120	Fastener-Bolt&Nut-Hex-8.8 Grade-M10x120-ZP
12	2	2880-0816	Fastener-Cap Head-Allen Screw-M8x16-316-Stainless
13	18	3010-0810	Fastener-Grub Screw-Socket Head-M8x10-Stainless
14	16	3075-0616	Fastener-Set-Screw-Hex-304 Grade-M6x16-Stainless
15	8	3075-0820	Fastener-Set-Screw-Hex-304 Grade-M8x20-Stainless
16	16	3075-0825	Fastener-Set Screw-Hex-M8x25-316-SS
17	8	3090-0200	Fastener-Machine-Screw-3/16"x1"-Slot-Stainless
18	2	3110-0465	Fastener-Machine-Screw-Pan-M4x65-Pozi-ZP
19	6	3110-0512	Fastener-Machine-Screw-Pan-M5x12-Pozi-ZP
20	16	3130-0106	Fastener-Nut-Nyloc-M6-Stainless Steel
21	8	3130-0108	Fastener-Nut-Nyloc-M8-Stainless Steel
22	8	3160-5101	Fastener-Nut-Nyloc-3/16 UNC-Stainless
23	2	3170-0004	Fastener-Nut-Nyloc-M4-ZP
24	28	3170-0008	Fastener-Nut-Nyloc-M8-ZP
25	17	3170-0010	Fastener-Nut-Nyloc-M10-ZP
26	4	3180-0008	Fastener-Nut-Plain-M8-ZP
27	1	3205-0200	Fastener-Pin-Roll-1/8"x3/4"-S/S
28	8	3240-0018	Fastener-Rivet-Blind-Truss Head-3/16x18mm-Aluminium
29	10	3280-1034	Fastener-Self Tap-Screw-Pan-10Gx3/4"-Pozi-ZP
30	2	3290-0820	Fastener-Set Screw-Hex-8.8 Grade-M8x20-ZP
31	2	3290-0850	Fastener-Set Screw-Hex-8.8 Grade-M8x50-ZP
32	4	3290-1025	Fastener-Set Screw-Hex-8.8 Grade-M10x25-ZP
33	2	3290-1030	Fastener-Set Screw-Hex-8.8 Grade-M10x30-ZP
34	8	3310-2809	Fastener-Washer-Flat-M8x22x1.5-Grade 316-Stainless
35	12	3310-2810	Fastener-Washer-Flat-M10x32x2.5-Grade 316-Stainless
36	10	3310-6008	Fastener-Washer-Flat-M8-ZP
37	10	3310-6010	Fastener-Washer-Flat-M10-ZP
38	2	3310-9200	Fastener-Washer-Flat-3/16"x1/2"x1.5-Grade 304-Stainless
39	8	3310-9210	Fastener-Washer-Flat-3/16"x7/8"x1.5-Grade 304-Stainless
40	2	3330-8008	Fastener-Washer-Spring-M8-ZP
41	4	3330-8010	Fastener-Washer-Spring-M10-ZP
42	1	3500-0300	Frame-3PL-CDIT1300-GL
43	1	3500-0301	Frame-3PL-CDIT1300 Actuator Pivot-ZP
44	1	3500-0302	Frame-3PL-CDIT1300 Hopper Cover Support-GL
45	1	3500-0303	Frame-3PL-CDIT1300 Hopper Tie Rail-ZP

46	1	3500-0304	Frame-3PL-CDIT1300 Hopper Tie Rail HEIGHT ADJUSTER-ZP
47	2	3800-1000	Gearbox-Ferroni-RV10-Ratio 1 to 2.78
48	1	3800-1220	Gearbox-Ferroni-RV-020-2.9:1 Ratio-1-3/8 Input-Two Output shafts
49	2	5050-7990	Linkage-Shutter-CDIT1300-ZP
50	2	5050-7991	Linkage-Shutter Swivel-CDIT1300-ZP
51	4	5200-6860	Machined-Shaft-Gearbox Connect-FENAFLEX-CDIT1300
52	2	5200-9200	Machined-Bush-Round-25 ODx14 Longx12 ID-ZP
53	2	6100-1100	Pin-Bottom Link-3 Point Linkage-ZPG
54	3	6100-4700	Pin-Linch-3 Point Linkage-ZPG
55	1	6100-8400	Pin-Top Link-3 Point Linkage-ZPG
56	2	6500-2165	Profiled-Disc-Spinner-Base-FORMED-CDIT 1300-Spreader-Stainless
57	2	6500-7770	Profiled-Shutter-CDIT300/400
58	8	6500-8955	Profiled-Vane-Spinner-Spreader-C-Dax 300/400/1300-Stainless
59	2	6500-9000	Profiled-Washer-Spinner Shaft-34.9x67x2mm-Stainless 304
60	1	7500-2117	Rota-Hopper-Spreader-CDIT1300 -Yellow-MDPE
61	1	7970-8123	Shroud-Spreader CDIT1300 MK3-MDPE-Yellow
62	1	7500-2830	Rota-Spout-Spreader-CDIT400GT-Yellow-MDPE
63	1	7500-2832	Rota-Spout-Spreader-CDIT1300-Counter Clockwise-Yellow-MDPE
64	2	8200-5200	Spinner-Mount-CDIT300/400/INEX300-ZP
65	1	8400-3800	Step-Goldline-800/1000L-GL
66	1	8800-1720	Tow-Coupling-Pin-P-Catch-10mm-ZPG
67	1	8800-1730	Tow-Coupling-Spring-Compression-ZP
68	4	8850-1200	U Bolt-Square-M8x66Longx48Centres-ZP
69	1	2600-1000	Drive Shaft-16HP-1000mm Long-Sheilded

PARTS DIAGRAM
(Units manufactured after May 2016)

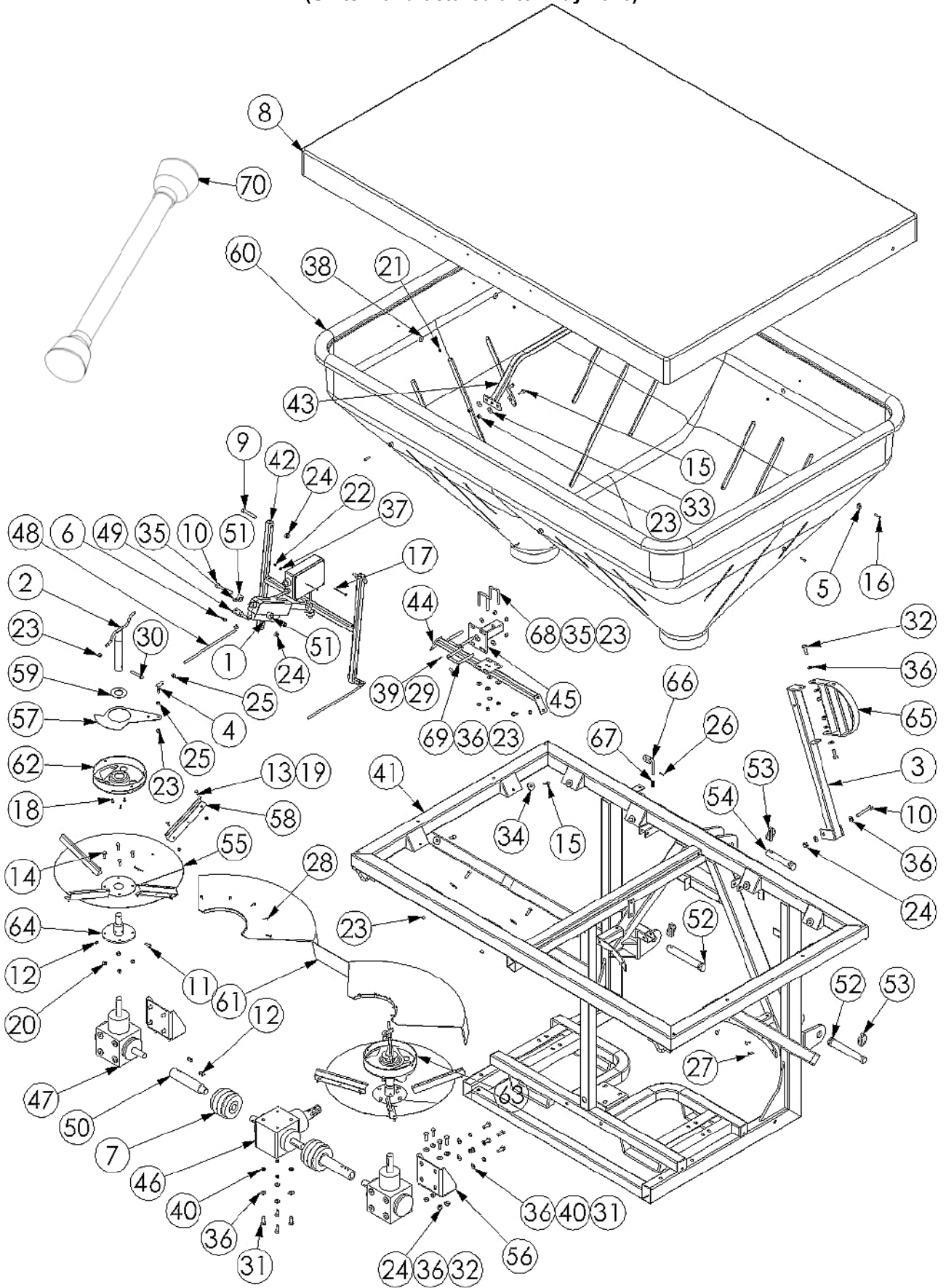

Actuator Controller Not Included in the Parts List

PARTS LIST
(Units manufactured after May 2016)

Item No	QTY	part no	Description
1	1	1010-2391	Actuator-Electrical-Smart Control-With Plug fitted
2	2	1036-8245	Agitator-Spreader-CDIT1300 G2-SS
3	1	1072-7500	Arm-Step-Goldline-800/1000L-GL
4	2	1110-2308	Ball-End-Internal Thread-M8-Zinc Plated
5	8	1455-8800	Button-Ute Cover-Bungy Cord Retain-Black-Plastic
6	2	2050-7350	Clip-R Type-Pin-2mm-ZP
7	2	2233-2525	Coupling-Drive-Duraflex-SET-DRC 110-Type F-25mm Bore Size- Includes Taperlock
8	1	2250-4110	Cover-Hopper-Blue Fabric-Spreader CDIT1300
9	3	2840-1065	Fastener-Bolt-Hex-8.8 Grade-M10x65-ZP
10	2	2840-1075	Fastener-Bolt-Hex-8.8 Grade-M10x75-ZP
11	2	2880-0816	Fastener-Cap Head-Allen Screw-M8x16-316-Stainless
12	10	3010-0810	Fastener-Grub Screw-Socket Head-M8x10-Stainless
13	16	3075-0616	Fastener-Set-Screw-Hex-304 Grade-M6x16-Stainless
14	8	3075-0820	Fastener-Set-Screw-Hex-304 Grade-M8x20-Stainless
15	16	3075-0825	Fastener-Set Screw-Hex-M8x25-316-SS
16	8	3090-0200	Fastener-Machine-Screw-3/16"x1"-Slot-Stainless
17	2	3110-0465	Fastener-Machine-Screw-Pan-M4x65-Pozi-ZP
18	6	3110-0512	Fastener-Machine-Screw-Pan-M5x12-Pozi-ZP
19	16	3130-0106	Fastener-Nut-Nyloc-M6-Stainless Steel
20	8	3130-0108	Fastener-Nut-Nyloc-M8-Stainless Steel
21	8	3160-5101	Fastener-Nut-Nyloc-3/16 UNC-Stainless
22	2	3170-0004	Fastener-Nut-Nyloc-M4-ZP
23	28	3170-0008	Fastener-Nut-Nyloc-M8-ZP
24	17	3170-0010	Fastener-Nut-Nyloc-M10-ZP
25	4	3180-0008	Fastener-Nut-Plain-M8-ZP
26	1	3205-0200	Fastener-Pin-Roll-1/8"x3/4"-S/S
27	8	3240-0018	Fastener-Rivet-Blind-Truss Head-3/16x18mm-Aluminium
28	10	3280-1034	Fastener-Self Tap-Screw-Pan-10Gx3/4"-Pozi-ZP
29	2	3290-0820	Fastener-Set Screw-Hex-8.8 Grade-M8x20-ZP
30	2	3290-0850	Fastener-Set Screw-Hex-8.8 Grade-M8x50-ZP
31	12	3290-1025	Fastener-Set Screw-Hex-8.8 Grade-M10x25-ZP
32	10	3290-1030	Fastener-Set Screw-Hex-8.8 Grade-M10x30-ZP
33	8	3310-2809	Fastener-Washer-Flat-M8x22x1.5-Grade 316-Stainless
34	12	3310-2810	Fastener-Washer-Flat-M10x32x2.5-Grade 316-Stainless
35	8	3310-6008	Fastener-Washer-Flat-M8-ZP
36	28	3310-6010	Fastener-Washer-Flat-M10-ZP
37	2	3310-9200	Fastener-Washer-Flat-3/16"x1/2"x1.5-Grade 304-Stainless
38	8	3310-9210	Fastener-Washer-Flat-3/16"x7/8"x1.5-Grade 304-Stainless
39	2	3330-8008	Fastener-Washer-Spring-M8-ZP
40	12	3330-8010	Fastener-Washer-Spring-M10-ZP
41	1	3500-0300	Frame-3PL-CDIT1300-GL
42	1	3500-0301	Frame-3PL-CDIT1300 Actuator Pivot-ZP
43	1	3500-0302	Frame-3PL-CDIT1300 Hopper Cover Support-GL
44	1	3500-0303	Frame-3PL-CDIT1300 Hopper Tie Rail-ZP
45	1	3500-0304	Frame-3PL-CDIT1300 Hopper Tie Rail HEIGHT ADJUSTER-ZP

46	1	3800-1220	Gearbox-Ferroni-RV-020-2.9:1 Ratio-1-3/8 Input-Two Output shafts
47	2	3800-1230	Gearbox-Ferroni-RV-020-1:2.9 Ratio-1 output shaft-input 25mm h7-output 25mm h7-mounting type E
48	2	5050-7990	Linkage-Shutter-CDIT1300-ZP
49	2	5050-7991	Linkage-Shutter Swivel-CDIT1300-ZP
50	2	5200-6870	Machined-Shaft-Gearbox Connect - DURAFLEX - CDIT1300 - G2 - ZP
51	2	5200-9200	Machined-Bush-Round-25 ODx14 Longx12 ID-ZP
52	2	6100-1100	Pin-Bottom Link-3 Point Linkage-ZPG
53	3	6100-4700	Pin-Linch-3 Point Linkage-ZPG
54	1	6100-8400	Pin-Top Link-3 Point Linkage-ZPG
55	2	6500-2165	Profiled-Disc-Spinner-Base-FORMED-CDIT 1300-Spreader-Stainless
56	2	6500-6029	Profiled-Plate-RV020 - CDIT1300 G2 - OUTER- Gearbox- Black Steel
57	2	6500-7770	Profiled-Shutter-CDIT300/400
58	8	6500-8955	Profiled-Vane-Spinner-Spreader-C-Dax 300/400/1300-Stainless
59	2	6500-9000	Profiled-Washer-Spinner Shaft-34.9x67x2mm-Stainless 304
60	1	7500-2117	Rota-Hopper-Spreader-CDIT1300 -Yellow-MDPE
61	1	7970-8123	Shroud-Spreader CDIT1300 MK3-MDPE-Yellow
62	1	7500-2830	Rota-Spout-Spreader-CDIT400GT-Yellow-MDPE
63	1	7500-2832	Rota-Spout-Spreader-CDIT1300-Counter Clockwise-Yellow-MDPE
64	2	8200-5180	Spinner-Mount-CDIT1300 G2-ZP
65	1	8400-3800	Step-Goldline-800/1000L-GL
66	1	8800-1720	Tow-Coupling-Pin-P-Catch-10mm-ZPG
67	1	8800-1730	Tow-Coupling-Spring-Compression-ZP
68	2	8850-1200	U Bolt-Square-M8x66Longx48Centres-ZP
69	2	8850-1220	U Bolt-Square-M10x85Longx63Centres-30Thread-ZP
70	1	2600-1000	Drive Shaft-16HP-1000mm Long-Sheilded

PARTS DIAGRAM – Trailer Kit

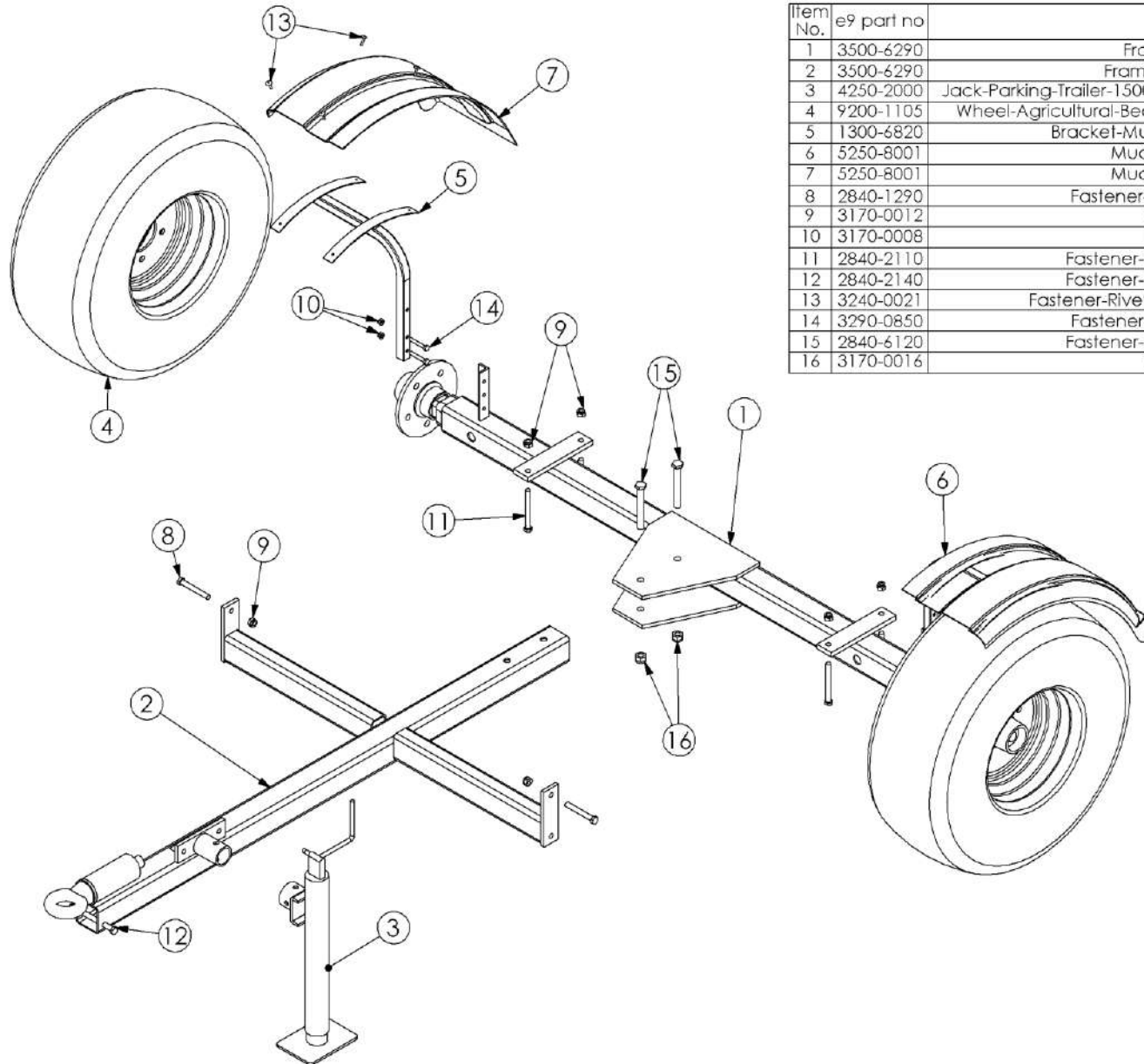

Item No.	e9 part no	e9 description	QTY.
1	3500-6290	Frame-Trailed-CDIT1300-Axle-GL	1
2	3500-6290	Frame-Trailed-CDIT1300-Drawbar-GL	1
3	4250-2000	Jack-Parking-Trailer-1500L-Top Wind-1300Kg-57Dia-L500-Incl mounting tube	1
4	9200-1105	Wheel-Agricultural-Bearing-10.0/80-12- 10 PLY-AW 5H-20Psi Tyre Pressure	2
5	1300-6820	Bracket-Mudguard-Goldline/CDIT1300 Trailed-GL	2
6	5250-8001	Mudguard-Trailer-1500L-MDPE-Blue	1
7	5250-8001	Mudguard-Trailer-1500L-MDPE-Blue	1
8	2840-1290	Fastener-Bolt&Nut-Hex-8.8 Grade-M12x90-ZP	2
9	3170-0012	Fastener-Nut-Nyloc-M12-ZP	7
10	3170-0008	Fastener-Nut-Nyloc-M8-ZP	4
11	2840-2110	Fastener-Bolt&Nut-Hex-8.8 Grade-M12x110-ZP	4
12	2840-2140	Fastener-Bolt&Nut-Hex-8.8 Grade-M12x140-ZP	1
13	3240-0021	Fastener-Rivet-Blind-Truss Head-3/16x21mm-Aluminium	8
14	3290-0850	Fastener-Set Screw-Hex-8.8 Grade-M8x50-ZP	4
15	2840-6120	Fastener-Bolt&Nut-Hex-8.8 Grade-M16x120-ZP	2
16	3170-0016	Fastener-Nut-Nyloc-M16-ZP	2

